

# Watt Avenue at Roseville Road Pedestrian and Bicycle Access Feasibility Study



Prepared for:  
Sacramento County Municipal Services Agency  
Department of Transportation

Prepared by:



2335 American River Drive, Suite 100

**Sacramento, CA 95825**

**Table of Contents**

1.	Introduction and Project Location .....	2
2.	Description of Existing Facilities.....	2
3.	Purpose and Need.....	4
4.	Pedestrian Grade Separated Crossings: Over or Under.....	5
5.	Proposed Alternatives.....	5
5.1	Discussion of Proposed Structure Type.....	6
5.2	Discussion of Proposed Construction Methods and Staging .....	6
6.	UPRR Review .....	7
7.	Preliminary Drawings .....	8
7.1	Combined General Plan.....	9
7.2	East Crossing General Plan .....	10
7.21	East Crossing Plan & Pump House Detail.....	11
7.22	Pathway Perspective.....	12
7.3	West Crossing General Plan .....	13
7.4	Stage 1 Plan .....	14
7.5	Stage 2 Plan .....	15
7.6	Stage 3 Plan .....	16
7.7	Stage 4 Plan .....	17
7.8	Stage 5 Plan .....	18
7.9	Advanced Planning – Underpass Replacement With Third UP Rail .....	19
8.	Schedules and Cost Estimates.....	20
	Design Schedule of East and or West Crossings .....	21
	Construction Schedule of East and or West Crossings .....	22
	Construction Cost Estimate of East and or West Crossings.....	23
9.	Supplemental Documents.....	24
	AECOM Comments Regarding Underpass Replacement Costs .....	25
	Final Invoice & Project Summary Comments .....	26

## **1. Introduction and Project Location**

The County of Sacramento Department of Transportation by way of this study considers the feasibility of various alternatives for creating a continuous north-south walk and bikeway through the area of the Union Pacific Railroad (UPRR) underpass on or adjacent to Watt Avenue and north of Roseville Road in Sacramento County.

Both UPRR and Sacramento County have identified safety issues within the area of the existing Watt Avenue underpass. The UPRR rail corridor at this location is heavily used and provides service for both UPRR freight and the Capitol Corridor Intercity Rail. The Capitol Corridor is a 170-mile passenger train corridor from Auburn and Sacramento to San Jose with a daily ridership of approximately 3,500 passengers. The tracks over Watt Avenue connect the Roseville and Sacramento stations on the Capitol Corridor line.



Figure 1: Aerial view of the Watt Ave/UPRR Grade Separation

## **2. Description of Existing Facilities**

The existing Watt Avenue UPRR underpass is a two-span, double track, ballasted, riveted steel through plate girder, with the tracks spaced approximately 14'-0" center-to-center. It is located within the UPRR Roseville Division, Martinez Subdivision at Mile Post (MP) 98.33; a segment of the track originally constructed by the Central Pacific Railroad in about 1864 and becoming a part of the UPRR in September 1996 when the UP acquired the Southern Pacific Railroad. The minimum vertical clearance over Watt Avenue to the UPRR underpass structure is approximately 15'-2".

Watt Avenue is a major north-south thoroughfare in Sacramento County with a posted speed limit of 35 miles per hour. Watt Avenue carries three lanes of traffic in both the northbound and southbound directions as it passes under the UPRR tracks. The horizontal clearance through the structure is constrained by the existing underpass abutments and center bent.

The original underpass was constructed in the 1950's as a single span structure over the existing two lane Watt Avenue; one lane of traffic in each direction. At that time the structure provided approximately 31'-4" of horizontal clearance between the faces of the abutments. Watt Avenue was widened in 1972 to provide three lanes of traffic in each direction. The original roadway was converted to southbound traffic only, with an added lane for a total of three (3) lanes now under the original span. The east abutment was converted to become the center bent in order to support a new easterly span accommodating the three lanes of Watt Avenue. Currently, the horizontal clearance for the northbound lanes is approximately 34'-6"; while the southbound traffic remains at about 31'-4" face to face of structure. The constrained horizontal clearance does not provide adequate clearance to include sidewalks or bike lane striping along Watt Avenue.



Figure 2: Existing Watt Ave UP looking to South

Currently, pedestrian and bicycle traffic along Watt Avenue must use the existing corrugated metal pipe (CMP) ped/bike underpass located to the west of the Watt Avenue [see photos of the west entrance to the CMP in Figure 3]. Access to the CMP underpass is over 150' west of Watt Avenue and obstructed from view making visibility of the pathway limited; isolating users and creating a security problem for those users.



Figure 3: Entrance to the existing CMP ped/bike underpass

It is not unusual to see cyclists crossing directly over the active UPRR tracks or traversing the UPRR underpass with the vehicular traffic rather than use the CMP underpass [see Figure 3].



Figure 4: Cyclists avoiding the CMP underpass are a significant safety concern

### 3. Purpose and Need

Sacramento County has identified the Watt Avenue Underpass as a choke point within this major transportation corridor and would like to widen Watt Avenue in the future to eliminate the constrained vehicular movements, while accommodating safe passage for bicycles and pedestrians on both sides of Watt. Although this widening is desirable and within the planning horizon, there is no funding currently identified.

While experienced urban cyclists can legally occupy the travelled way with motor vehicles, the speed and volume of the traffic, coupled with the reduced lane and shoulder widths through the underpass makes use of the Watt Avenue Underpass by bike users very undesirable. Pedestrians proceeding north or south along Watt Avenue must use the previously described CMP underpass on the west side of the corridor or detour to the east and cross the UPRR tracks on the Airbase Drive Overhead, adding approximately ½ mile to their trip. While the approaches to the CMP underpass are isolated and have restricted visibility, resulting in security and safety concerns

The Airbase Drive route is not an efficient route for either north or south bound pedestrian and bicycle movements making it inconvenient to use. Indeed users that are unfamiliar with the area would not necessarily even be aware of the choice to use the CMP to the west or Airbase Drive to the east.



 **Figure 5: A few of the frequently used “alternate” dangerous routes taken by pedestrians and cyclists across UPRR tracks are in proximity to the “skull & cross bones” symbols.**

These conditions have resulted in frustrated and impatient pedestrian and bicycle users trespassing on the UPRR right-of-way (ROW) in order to climb the railroad embankment and cross the active tracks at-grade. Such illegal at-grade crossings of the tracks can have grave consequences for both trespasser(s) and the freight and passenger trains using the tracks. The pedestrian and bicycle crossings are frequent enough that paths across the tracks are visible in the aerial photo shown in Figure 5: above identified by the “skull & crossbones” symbols.

Sacramento County is investigating options to provide safe passage for both pedestrians and bicyclists through the Watt Avenue Underpass area which will alleviate safety issues resulting from the frequent illegal at-grade crossings of the UPRR tracks at Watt Avenue. Providing facilities to grade separate the

pedestrian and bicycle movements and the UPRR tracks at Watt Avenue will also encourage more people to walk and bike along this critical segment of Watt Avenue once it is safer to do so.

#### **4. Pedestrian Grade Separated Crossings: Over or Under**

The effectiveness of grade separated crossings depends heavily upon whether or not the users perceive the facility accessibility and ease of use. Often times it is perceived to be more efficient to cross at grade rather than to use the grade separated crossing. Users weigh the perceived safety benefits against effort and time issues. To maximize the use of grade separated crossings, they should be located in the normal or expected path of major pedestrian and bicycle user movements. Pedestrians almost always favor the shortest route; therefore, a facility that is inconvenient to access or is on an indirect path will simply not be used.

The most direct and effective separation would be achieved by the addition of dedicated pedestrian and bicycle pathways directly adjacent to the travelled way along Watt Avenue; however, this would require replacement of the existing underpass, which although desirable this would be a much longer term solution due to its expense and current funding sources.

The goal of this study was to also identify “short term” or intermediate options. We are then left with two options: 1) go over the tracks, or 2) go under the tracks. Recalling the convenience principle and considering the fact that the tracks are located on an elevated embankment, a pedestrian path over the tracks would have to rise almost 40 feet in the air to provide the required vertical clearance over the UPRR (23'-6": top of rail to low structure element). Users would need to ascend the height by use of stairs, an elevator or lengthy ramps that would have to accommodate users with limited mobility. Climbing up stairs or a ramp the equivalent height of a four story building would challenge the convenience test for most pedestrians; although, the ramps would present an inviting challenge to skateboard enthusiasts; therefore, this option of going over the tracks with a ped/bike path is not a desirable consideration.

With tracks on an elevated embankment, “going under” or an underpass type of grade separated crossing reduces the required elevation climb of the users. The underpass type facility works best when designed to feel open, well-lit and safe. Security for users may be a concern if the facility is isolated or obstructed from view, such as the existing culvert crossing; however, this can be minimized with our proposed alternative (see Figure 6.).

#### **5. Proposed Alternatives**

Sacramento County’s preferred proposed alternative is to construct pedestrian and bike access along Watt Avenue with grade separated crossings under the UPRR tracks. The paved mixed use pedestrian/bike paths will be located adjacent to and provide access for both the east and west sides of Watt Avenue. The existing cut slopes along Watt Avenue will be re-graded to provide unobstructed views of the pedestrian and bike underpass. The path will curve away from Watt Avenue and cross under the UPRR tracks behind the existing wingwalls, at an angle perpendicular to the tracks to minimize the length and complexity of the structure required to carry the UPRR tracks over the path. The approach path to the proposed ped/bike underpass structure and the retaining walls at the entrance of the underpass will be arranged to provide views of the facility from Watt Avenue that are as unobstructed as possible from along the path and from Watt Avenue.

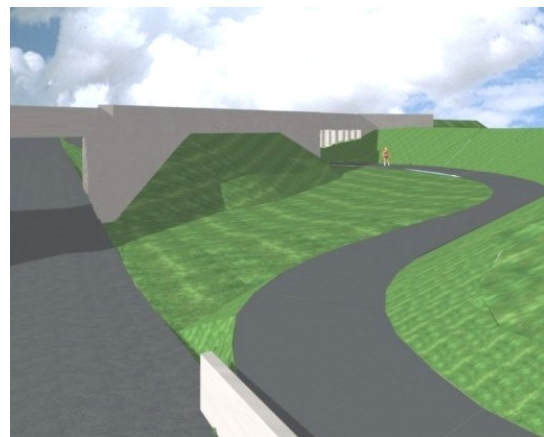

Figure 6: Conceptual view of ped/bike path from Northbound Watt Ave

## 5.1 Discussion of Proposed Structure Type

The proposed underpass structures would utilize a UPRR Standard Plan pre-cast (PC), pre-stressed (PS) concrete double cell box girder type structure. Each girder is 7 feet wide, and two girders are placed side-by-side to support a single track. A 34'-0" long, single-span arrangement is proposed with the girder ends bearing on UPRR Standard Plan PC concrete end bents, supported by driven H-Piling. Embankment material behind each end bent would be retained by steel sheet piling.

The piling supporting the end bents may be enclosed with additional precast concrete panels or a concrete block retaining wall and backfilled with "flowable" backfill; or some other type of enclosure configured to meet both pathway user safety and railroad design and maintenance requirements

A precast concrete fascia beam that will create a 2'-6" wide UPRR maintenance walkway and include a chain link fence will be provided on both sides of the deck. The fascia beam with chain link fence will satisfy the protective cover requirements as stated in Section 7.3.2.2 of the *"BNSF Railway – Union Pacific Railroad Guidelines for Railroad Grade Separation Projects"*.

Wingwalls will be constructed from a modular precast concrete wall system ["T-Wall"], arranged to open up the view to the entrance of the path thru the underpass to nearby Watt Avenue.

## 5.2 Discussion of Proposed Construction Methods and Staging

The use of a "shoo-fly" or temporary track to route the existing rail traffic away from the construction would be prohibitively expensive. A shoo-fly would require substantial embankment and track construction for the approaches to Watt Avenue; a temporary railroad underpass on Watt Ave.; and likely modification of the Watt Ave. roadway profile to accommodate the necessary vertical clearance between Watt and the temporary UPRR underpass structure.

The proposed pedestrian/bicycle underpass does not require the use of a "shoo-fly" because the capital cost of using this approach is expected to be in excess of 60% of the reconstruction of the existing vehicular underpass. As previously stated, no funding is currently identified that could support the replacement. While the use of a "shoo-fly" is certainly the preferred method of maintaining safe rail operations during construction of any structure to carry trains; the proposed solution can and has been executed safely by others, including the UPRR, in the Sacramento area. The proposed solution would not utilize a shoo-fly to construct the proposed pedestrian/bicycle underpass; rather, it would limit UPRR operations to single track operation while the pedestrian underpass structure is installed under each track, one at a time.

Operations would then shift to the other track while the second half of the underpass structure is constructed. The process would require the use of existing crossovers or the installation of new ones to facilitate single track operation.

The following describes the anticipated sequence of activities required to construct the underpass structure without the use of a shoo-fly track, while maintaining rail traffic. It is assumed that all the appropriate safety measures required by UPRR have been incorporated by design and field operations are conducted under the watchful eye of trained UPRR flagmen.

### Stage 1

1. Shift to single track operations (all rail traffic on Track No. 1).
2. Place temporary sheet piling between the existing tracks; remove section of Track No. 2 track; excavate sufficient material to allow installation of piling and precast concrete end bent.
3. Drive the HP piling; cut off piles to receive precast concrete end bents.
4. Place precast concrete end bent on HP piles and complete welded connection.
5. Install sheet pile cut-off walls behind backwall of each PC concrete end bent.

Stage 2

1. Excavate track bed between end bents; install PC/PS concrete box girders, PC concrete fascia beams, wingwalls, T-wall units and temporary ballast curb.
2. Backfill behind end bents.
3. Place waterproofing, ballast, and re-install Track No. 2 track.
4. Shift traffic to Track No. 2 track single track operation).

Stage 3

1. Remove portion of temporary sheet piling between tracks
2. Remove portion of Track No. 1 track & excavate
3. Drive HP piling
4. Set precast end bents
5. Install sheet pile cut-off walls behind end bents

Stage 4

1. Excavate track bed between end bents; install PC/PS concrete box girders, PC concrete fascia beams, wingwalls, T-wall units.
2. Backfill behind end bents.
3. Remove temporary ballast curb. Complete water proofing, place ballast and reinstall track
4. Remove remaining temporary sheet piling between tracks; fill any voids with flowable backfill or grout
5. Resume double track operations

Stage 5

1. Excavate beneath installed concrete girders
2. Construct retaining wall in front of piling at each end bent
3. Place flowable backfill behind retaining wall
4. Construct paved pedestrian/bicycle path
5. Install chain link fence

**6. UPRR Review**

Sacramento County is anticipating partnering with UPRR in the construction of this project. It will be necessary to develop a Memorandum of Understanding (MOU) that details cost share and responsibilities prior to the commencement of any project. In order to minimize impacts to UPRR operations, Sacramento County proposes that the construction of the underpass structure be performed by a UPRR contractor. The approaches to, and the pedestrian/bike path through the underpass structure would be constructed by a Sacramento County contractor.

The viability of this project is contingent upon the agreement of UPRR to allow the pedestrian/bike grade separation underpass structures to be built in stages.



**7. Preliminary Drawings**

**7.1 Combined General Plan**

**7.2 East Crossing General Plan**

**7.21 East Crossing Plan & Pump House Detail**

**7.22 Pathway Perspective**

**7.3 West Crossing General Plan**

**7.4 Stage 1 Plan**

**7.5 Stage 2 Plan**

**7.6 Stage 3 Plan**

**7.7 Stage 4 Plan**

**7.8 Stage 5 Plan**

**7.9 Advanced Planning – Underpass Replacement With Third UP Rail**

**8. Schedules and Cost Estimates**

**Design Schedule of East and or West Crossings**

**Construction Schedule of East and or West Crossings**

**Construction Cost Estimate of East and or West Crossings**

**9. Supplemental Documents**

**AECOM Comments Regarding Underpass Replacement Costs**

**Final Invoice & Project Status Summary**

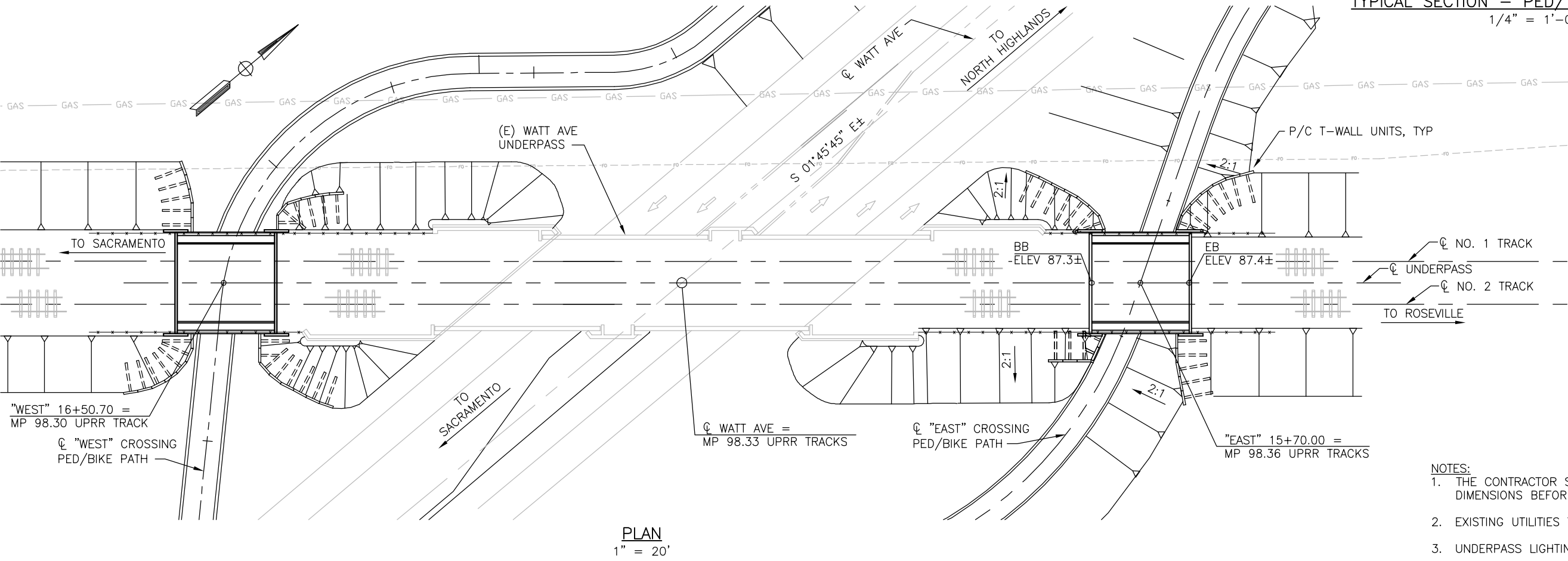
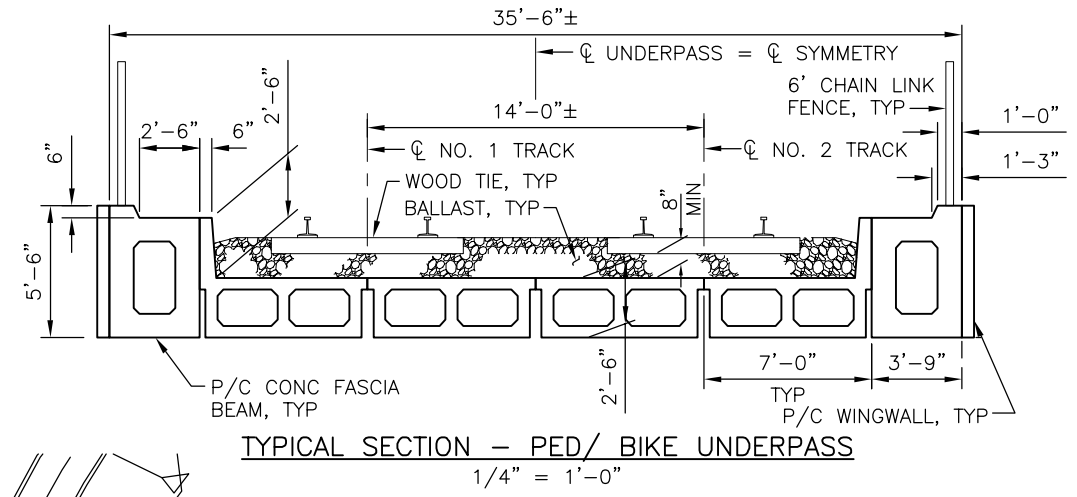
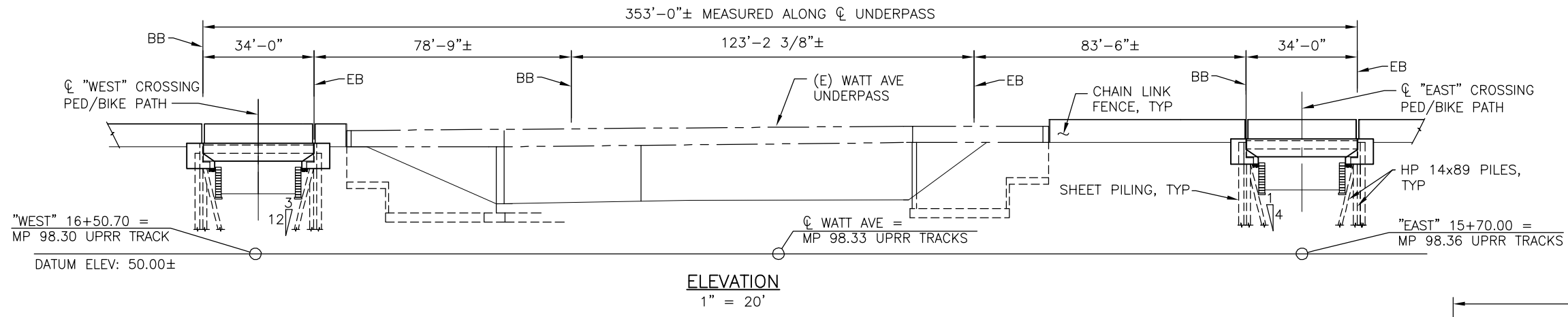

- NOTES:
1. THE CONTRACTOR SHALL VERIFY ALL CONTROLLING FIELD DIMENSIONS BEFORE ORDERING OR FABRICATING ANY MATERIAL.
  2. EXISTING UTILITIES TO BE PROTECTED IN PLACE.
  3. UNDERPASS LIGHTING NOT SHOWN.

I:\Sac\_County\60050869 Watt-Roseville\CADD\Struct\Sheet\S-01\_East\_West\_Combined.dwg Time:Apr/29/2010 - 03:32pm  
 Login:Waltz Dimas:08 L1Scale:1 Images:  
 Xrefs: XREF.dwg XREF.dwg

REVISIONS				
MARK	DATE	DESCRIPTION	BY	CHKD
△				
△				
△				
△				

SCALE: VERTICAL: \_\_\_\_\_  
 HORIZONTAL: \_\_\_\_\_

ORIGINAL SCALE IN INCHES  
 FOR REDUCED PLAN

PROJECT ENGINEER: THOMAS R. BARNARD REG. NO. C46384 DATE 3/31/11

DESIGNED BY: \_\_\_\_\_

DRAWN BY: \_\_\_\_\_

CHECKED BY: \_\_\_\_\_

**AECOM**  
 Technical Services, Inc.  
 2335 American River Drive, Suite 100  
 Sacramento, CA. 95825

Prepared for  
 Sacramento County Municipal  
 Services Agency  
 Department of Transportation

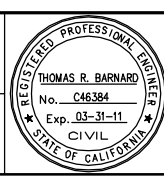

CI: \_\_\_\_\_

FILE: \_\_\_\_\_

DWG#: \_\_\_\_\_

WATT AVENUE AT ROSEVILLE ROAD  
 PEDESTRIAN & BICYCLE ACCESS IMPROVEMENTS

LAYOUT  
 Combined General Plan

7.1  
 SHEET  
 OF

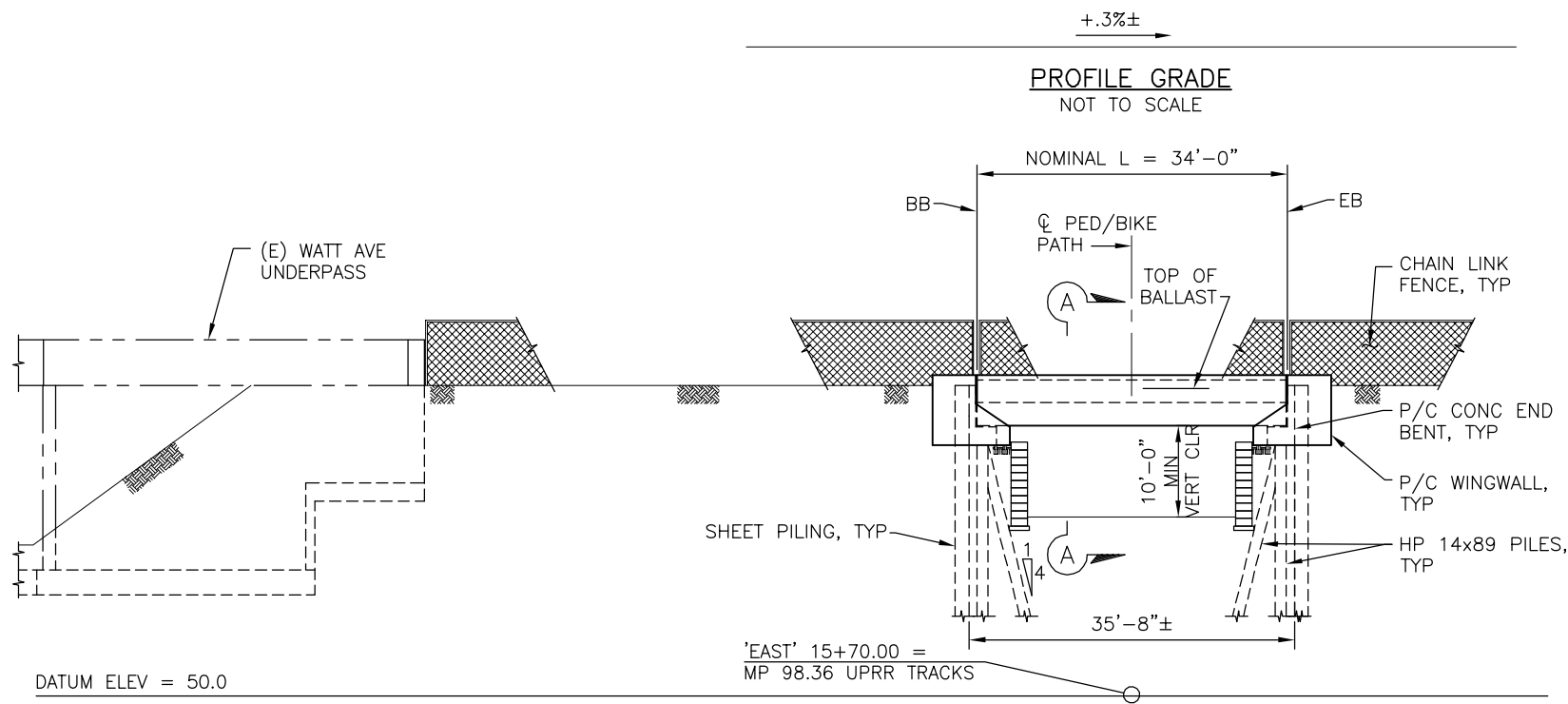

**ELEVATION**  
1" = 10'

NOTE:  
PRECAST T-WALL UNITS NOT SHOWN FOR CLARITY.

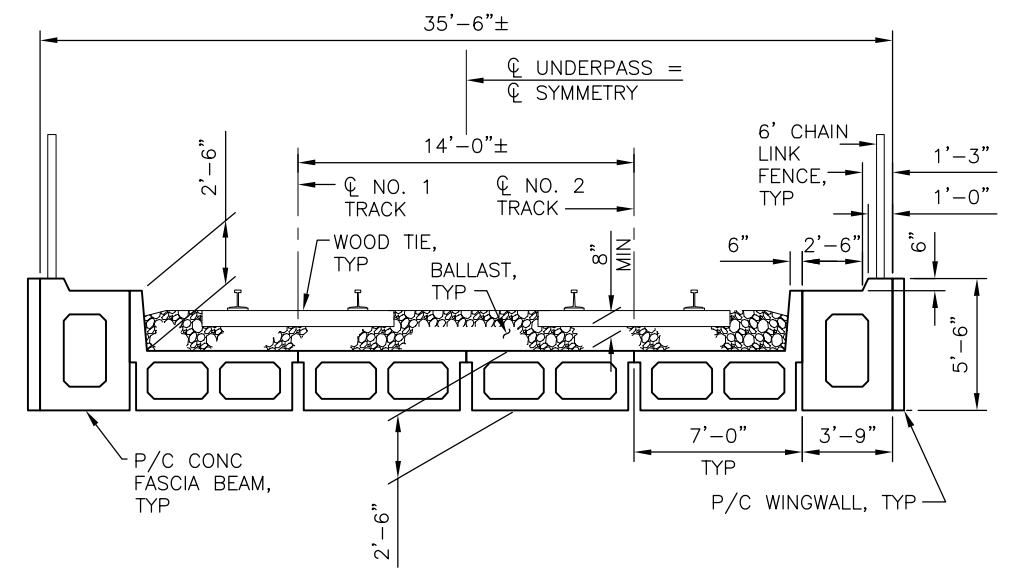

**SECTION A-A**  
1/4" = 1'-0"

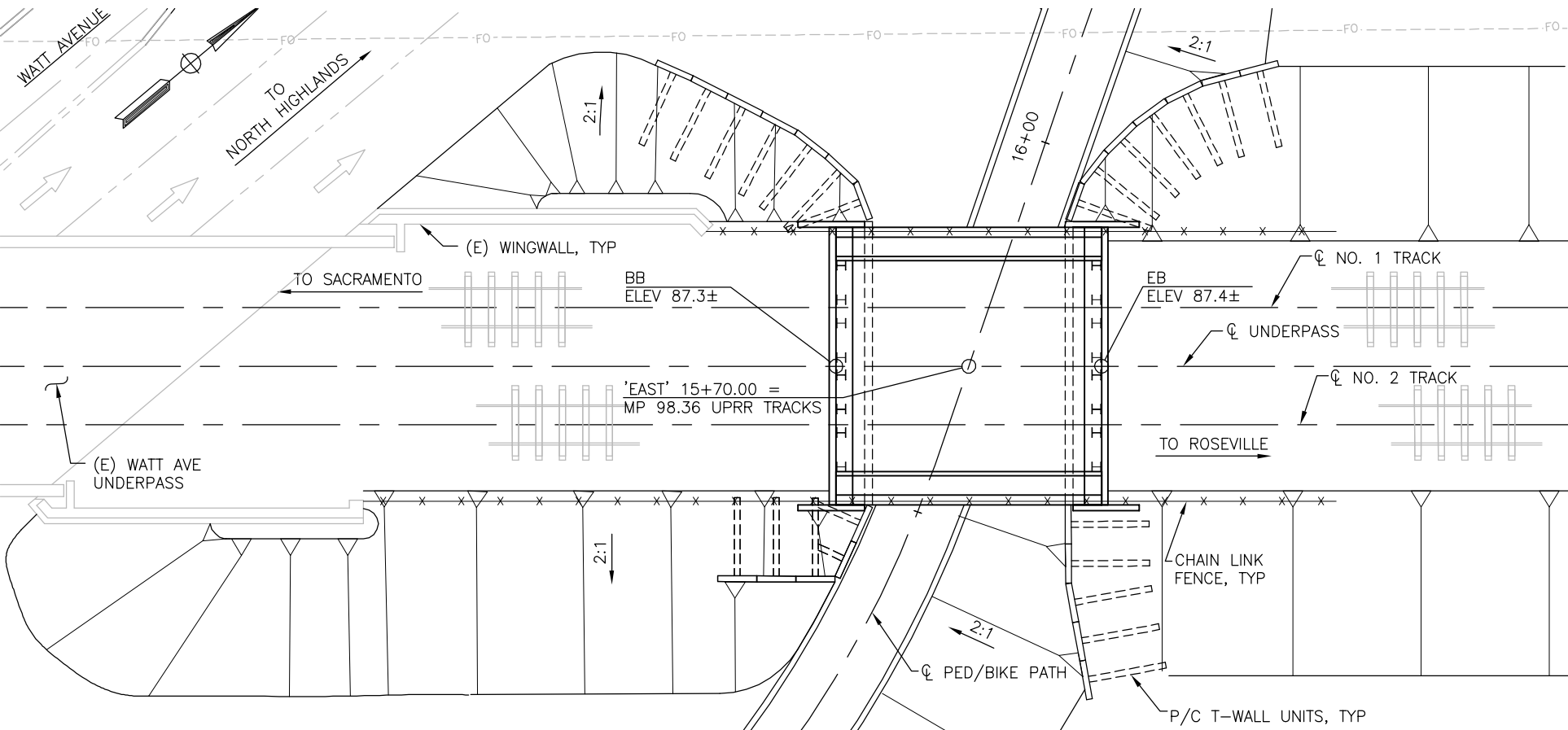

**PLAN**  
1" = 10'

NOTE:  
1. THE CONTRACTOR SHALL VERIFY ALL CONTROLLING FIELD DIMENSIONS BEFORE ORDERING OR FABRICATING ANY MATERIAL.

I:\Sac\_County\6050969 Watt-Roseville\CA00\Struct\Sheet\S-01\_East\_Crossing\_GP.dwg Time:Apr/29/2010-03:32pm Login:Waltz Dimascale:08 LScale:1 Images: Xrefs: XREF.dwg XREF.dwg XSTRUCT-ALL.dwg XSTRUCT-ALL.dwg

REVISIONS				
MARK	DATE	DESCRIPTION	BY	CHKD

SCALE: VERTICAL: \_\_\_\_\_  
HORIZONTAL: \_\_\_\_\_

ORIGINAL SCALE IN INCHES FOR REDUCED PLAN

PROJECT ENGINEER: THOMAS R. BARNARD REG. NO. C46384 DATE 3/31/11

DESIGNED BY: \_\_\_\_\_

DRAWN BY: \_\_\_\_\_

CHECKED BY: \_\_\_\_\_

**AECOM**  
Technical Services, Inc.  
2335 American River Drive, Suite 100  
Sacramento, CA. 95825

Prepared for  
Sacramento County Municipal  
Services Agency  
Department of Transportation

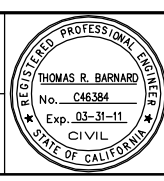

CI: \_\_\_\_\_

FILE: \_\_\_\_\_

DWG#: \_\_\_\_\_

**WATT AVENUE AT ROSEVILLE ROAD  
PEDESTRIAN & BICYCLE ACCESS IMPROVEMENTS**

**GENERAL PLAN - EAST CROSSING**

7.2  
SHEET  
OF

I:\Sacramento\60050869\Watt-Roseville\CA00\Struct\Sheet\S-01\\_ALT\_1.dwg Time: Apr 30, 2010 - 07:47 am  
 Login: Wlz7 Dim: scale: 1' = 5'0" Images: Xrefs: I:\Sacramento\60050869\Watt-Roseville\CA00\Struct\Sheet\S-01\\_ALT\_1.dwg XREF: I:\Sacramento\60050869\Watt-Roseville\CA00\Struct\Sheet\S-01\\_ALT\_1.dwg  
 AECOM  
 CHECKING PRINT NO. \_\_\_\_\_ CHECKED BY: \_\_\_\_\_ DATE: \_\_\_\_\_  
 CORRECTED BY: \_\_\_\_\_ DATE: \_\_\_\_\_  
 B' CHECKED BY: \_\_\_\_\_ DATE: \_\_\_\_\_  
 SIGNED BY: \_\_\_\_\_ DATE: \_\_\_\_\_

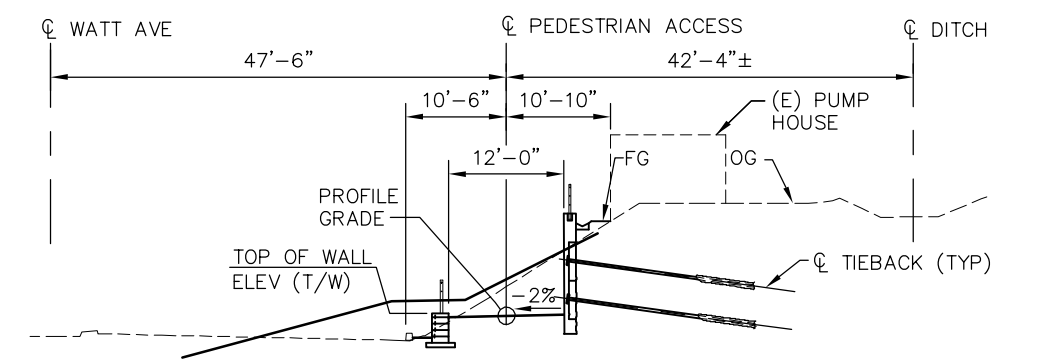
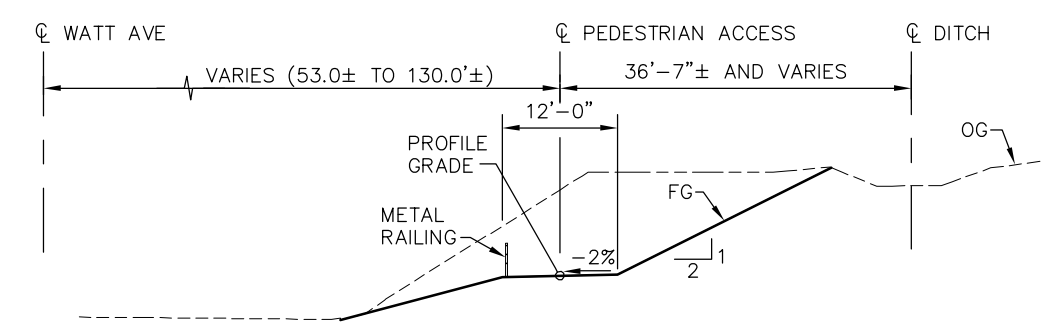
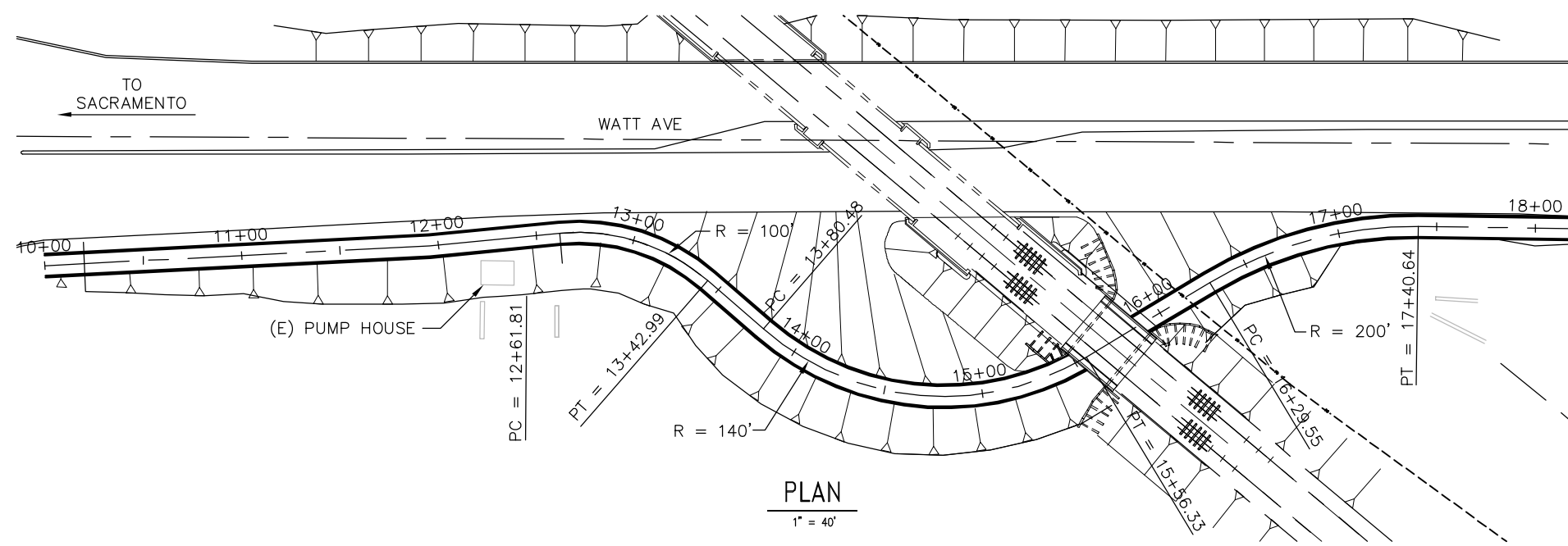
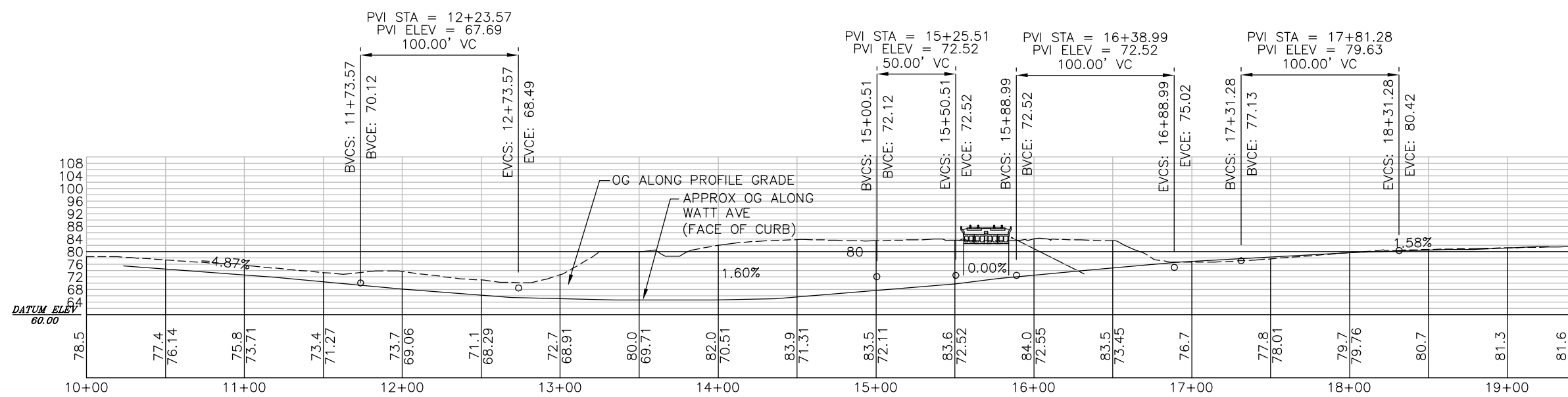

**DRAFT - NOT FOR CONSTRUCTION**

REVISIONS				
MARK	DATE	DESCRIPTION	BY	CHKD
△				
△				
△				
△				

SCALE: VERTICAL: \_\_\_\_\_  
 HORIZONTAL: \_\_\_\_\_  
 ORIGINAL SCALE IN INCHES  
 FOR REDUCED PLAN

PROJECT ENGINEER: THOMAS R. BARNARD  
 DESIGNED BY: \_\_\_\_\_  
 DRAWN BY: \_\_\_\_\_  
 CHECKED BY: \_\_\_\_\_  
 REG. NO. C46384  
 DATE 3/31/11

**AECOM**  
 Technical Services, Inc.  
 2335 American River Drive, Suite 100  
 Sacramento, CA. 95825  
 Prepared for  
 Sacramento County Municipal  
 Services Agency  
 Department of Transportation

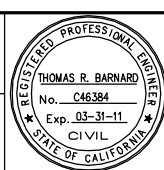

CI:  
 FILE:  
 DWG#:

WATT AVENUE AT ROSEVILLE ROAD  
 PEDESTRIAN & BICYCLE ACCESS IMPROVEMENTS  
 PLAN AND PROFILE  
 East Crossing & Pump House Detail

7.21  
 SHEET  
 OF



Pathway Perspective 7.22

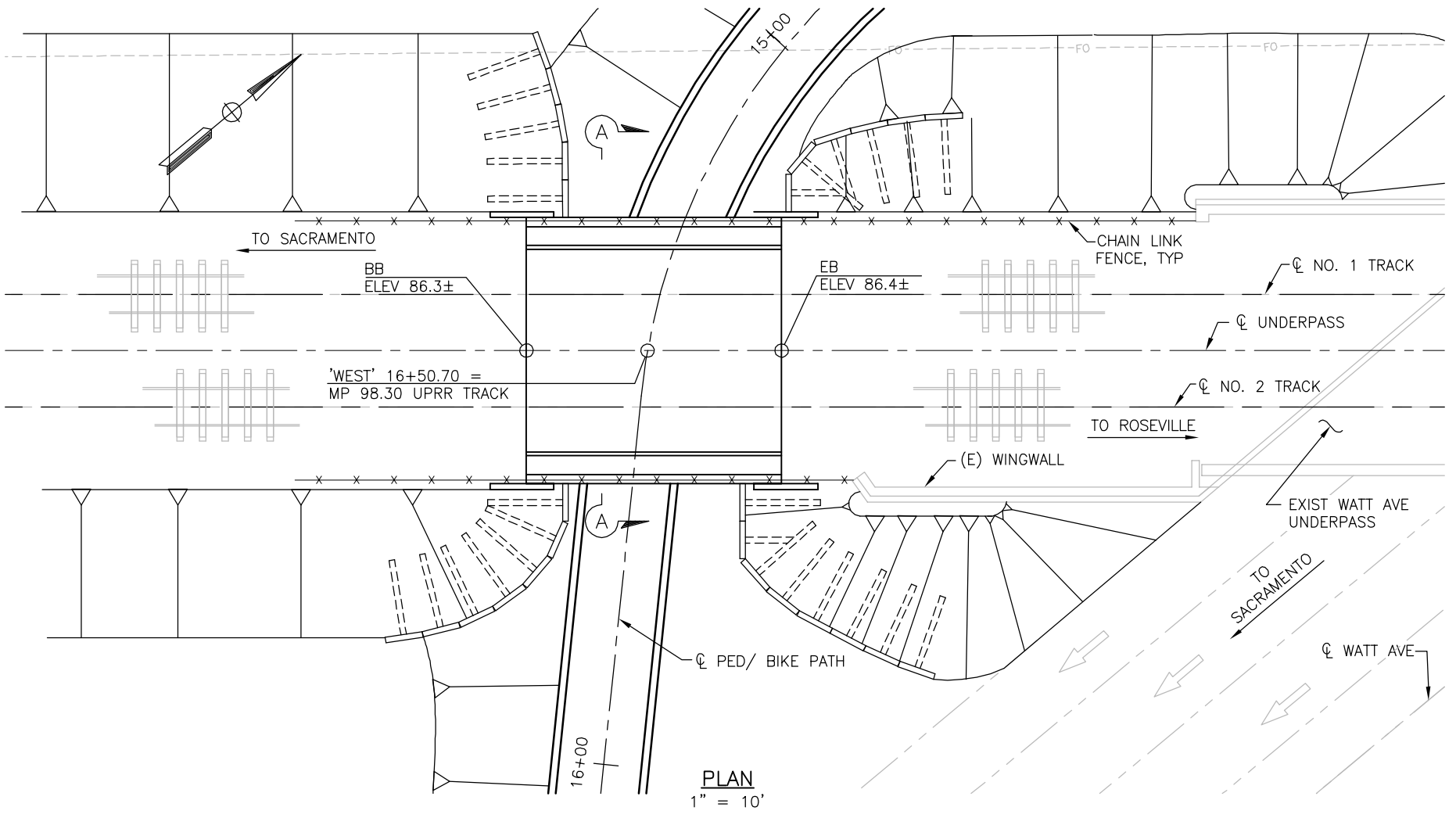
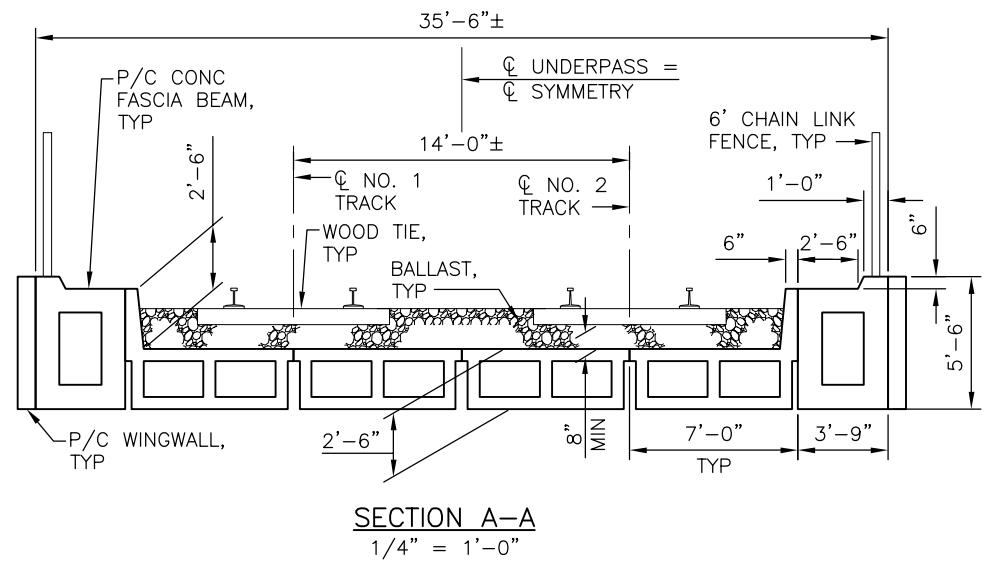
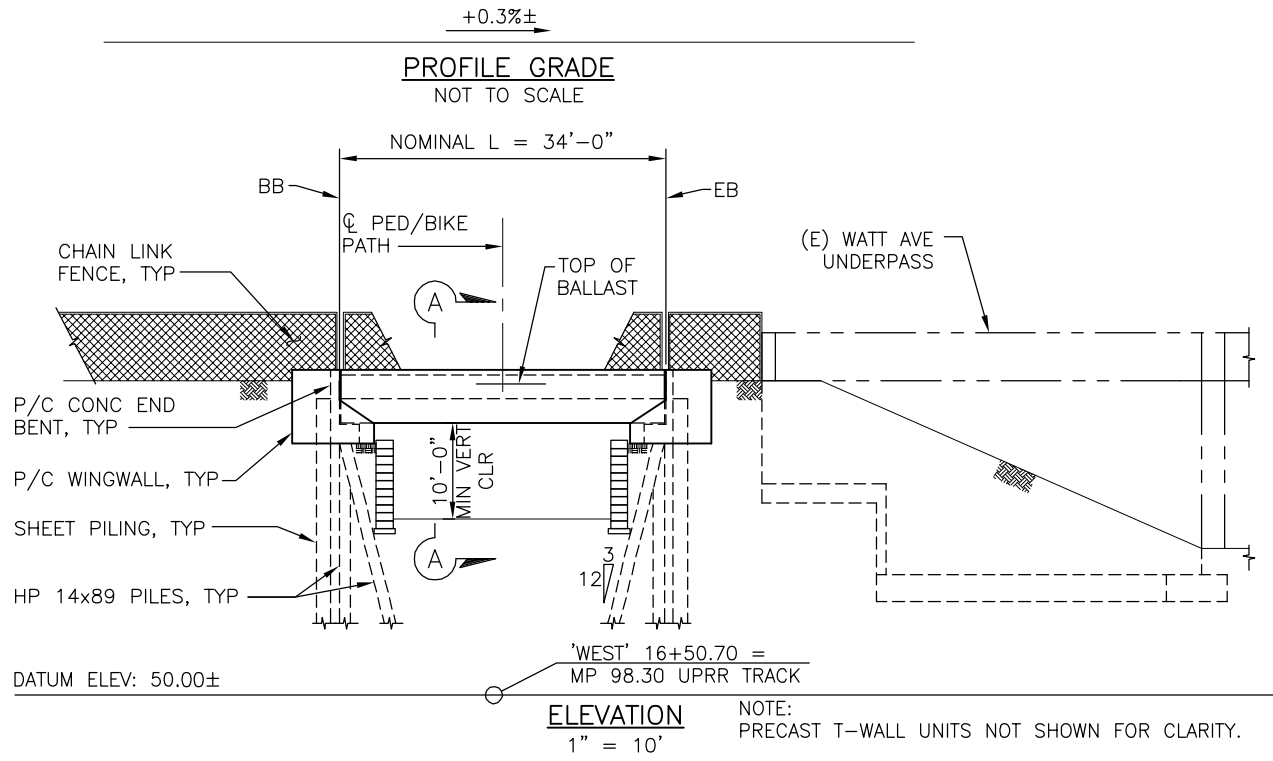

NOTES:  
1. THE CONTRACTOR SHALL VERIFY ALL CONTROLLING FIELD DIMENSIONS BEFORE ORDERING OR FABRICATING ANY MATERIAL.

I:\Sac\_County\60050869 Watt-Roseville\CADD\Struct\Sheet\S-01\_West Crossing\_GP.dwg Time:Apr23,2010-03:35pm Log:Waltz Dimas:rb L:\Scale:1 Images: X:\STRUCT-ALT.dwg X:\STRUCT-ALT.dwg X:\STRUCT-ALT.dwg

REVISIONS				
MARK	DATE	DESCRIPTION	BY	CHKD

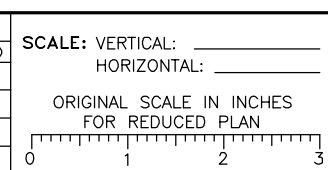

PROJECT ENGINEER: THOMAS R. BARNARD  
DESIGNED BY: \_\_\_\_\_  
DRAWN BY: \_\_\_\_\_  
CHECKED BY: \_\_\_\_\_

REG. NO. C46384  
DATE 3/31/11

**AECOM**  
Technical Services, Inc.  
2335 American River Drive, Suite 100  
Sacramento, CA. 95825

Prepared for  
Sacramento County Municipal  
Services Agency  
Department of Transportation

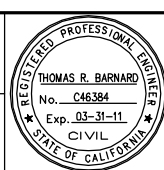

CI: \_\_\_\_\_  
FILE: \_\_\_\_\_  
DWG#: \_\_\_\_\_

WATT AVENUE AT ROSEVILLE ROAD  
PEDESTRIAN & BICYCLE ACCESS IMPROVEMENTS

GENERAL PLAN - WEST CROSSING

7.3  
SHEET  
OF

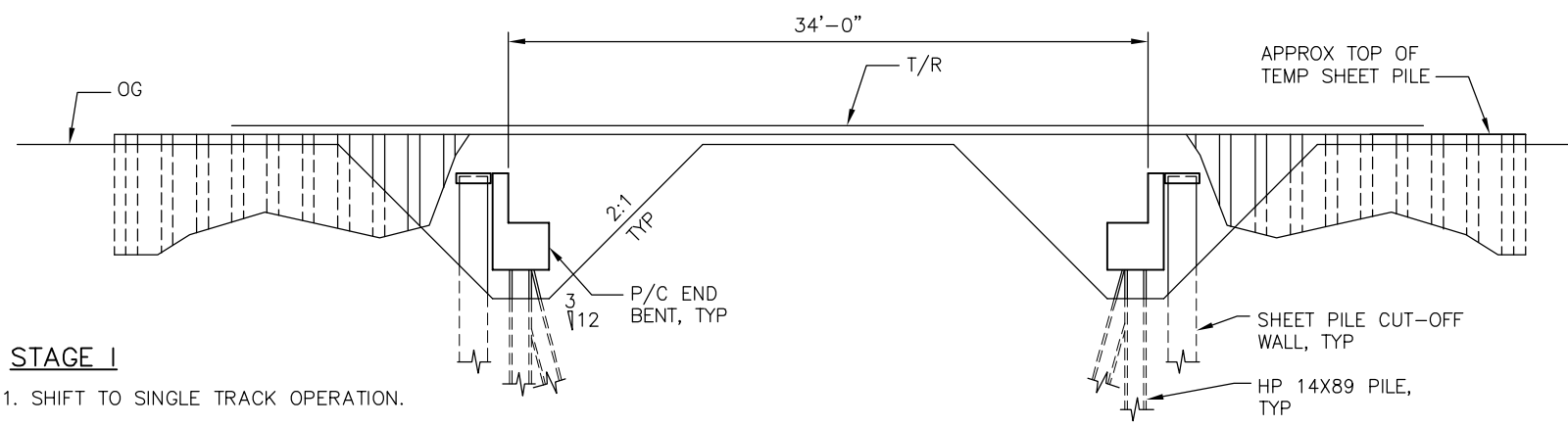

- STAGE I**
1. SHIFT TO SINGLE TRACK OPERATION.
  2. PLACE TEMPORARY SHEET PILE BETWEEN NO. 2 AND NO. 1 TRACKS, REMOVE NO. 2 TRACK AND EXCAVATE.
  3. DRIVE HP PILES.
  4. SET PRECAST CONCRETE END BENTS.
  5. INSTALL SHEET PILE CUT-OFF WALLS BEHIND END BENTS.

**SECTION A - STAGE I**  
1" = 5'

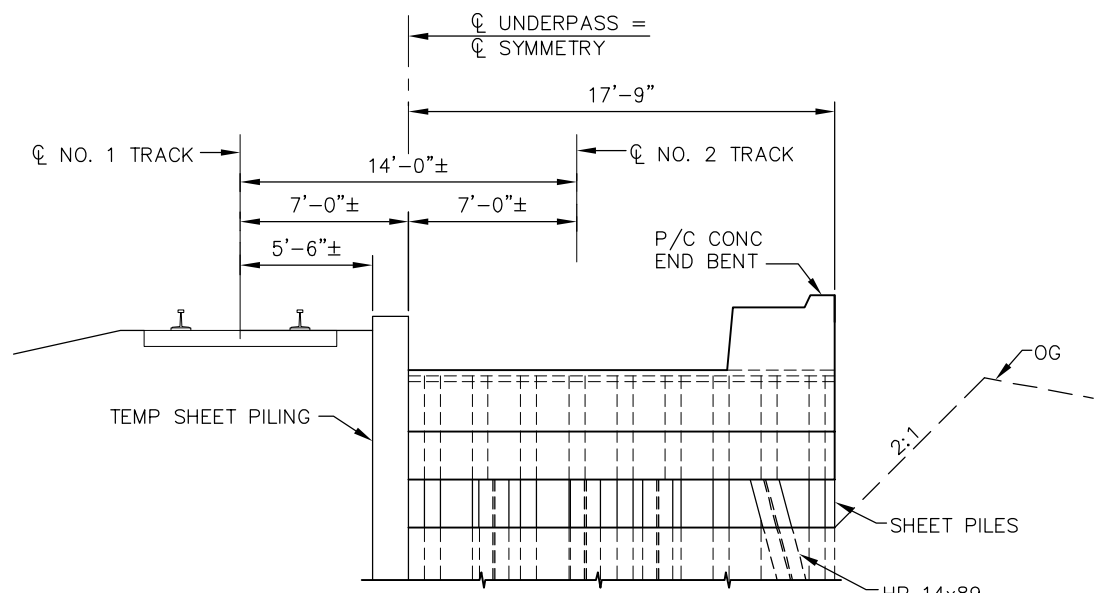

**SECTION B - STAGE I**  
1/4" = 1'-0"

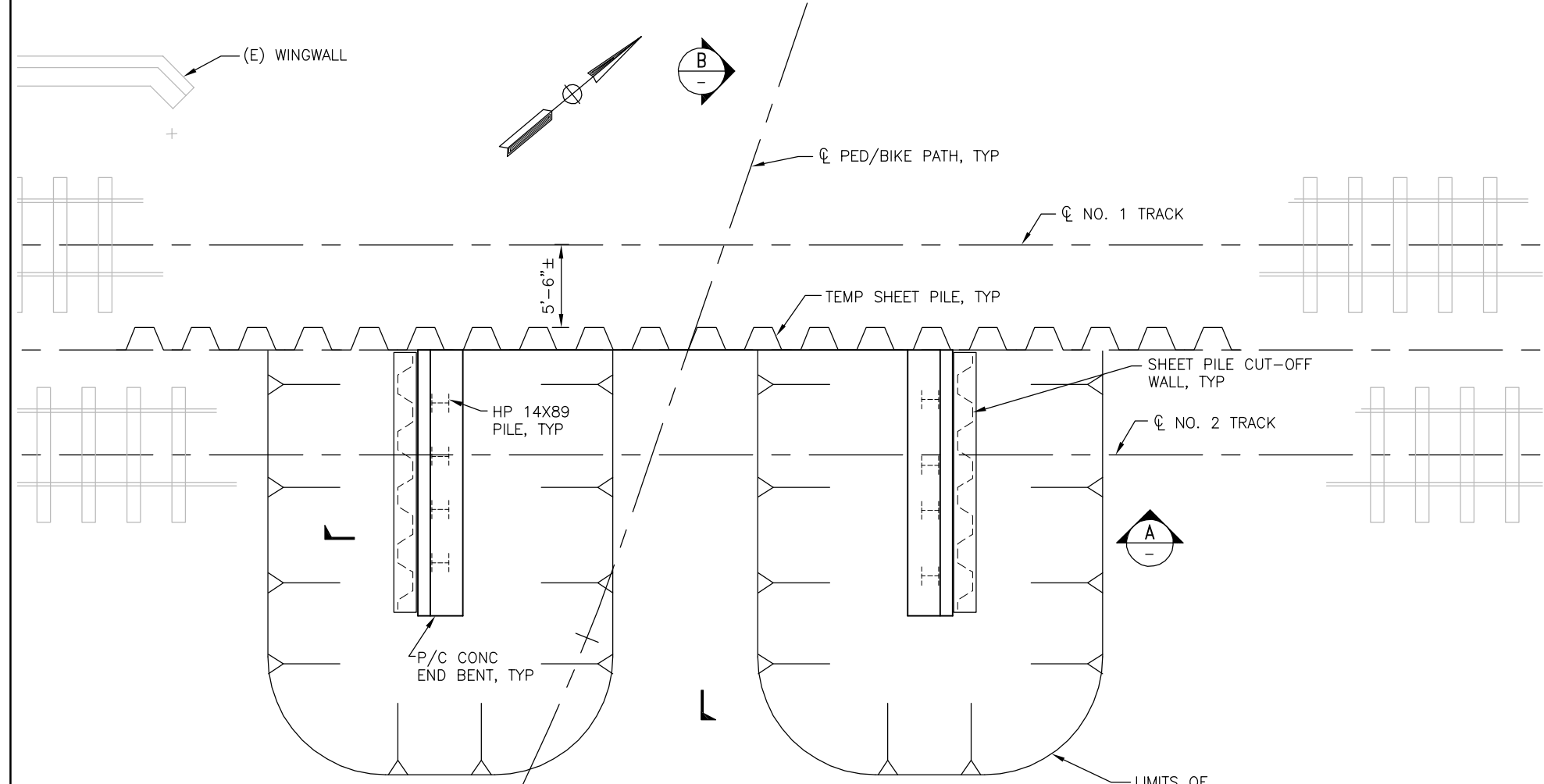

**PLAN - STAGE I**  
1" = 5'

# STAGE I

I:\Sac\_County\60050869\_Watt-Roseville\CADD\Struct\Sheet\S-04.dwg Time:Apr29,2010-05:36pm  
Log:WaltZ DimScale:1/8 1/8 Scale:1  
Xref: XREF - S.dwg

REVISIONS				
MARK	DATE	DESCRIPTION	BY	CHKD
△				
△				
△				
△				

SCALE: VERTICAL: \_\_\_\_\_  
HORIZONTAL: \_\_\_\_\_  
ORIGINAL SCALE IN INCHES  
FOR REDUCED PLAN

PROJECT ENGINEER: THOMAS R. BARNARD  
DESIGNED BY: \_\_\_\_\_  
DRAWN BY: \_\_\_\_\_  
CHECKED BY: \_\_\_\_\_

REG. NO. C46384 DATE 3/31/11  
**AECOM**  
Technical Services, Inc.  
2335 American River Drive, Suite 100  
Sacramento, CA. 95825  
Prepared for  
Sacramento County Municipal  
Services Agency  
Department of Transportation

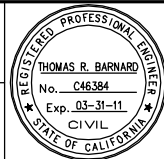

CI: \_\_\_\_\_  
FILE: \_\_\_\_\_  
DWG#: \_\_\_\_\_

WATT AVENUE AT ROSEVILLE ROAD  
PEDESTRIAN & BICYCLE ACCESS IMPROVEMENTS  
Stage 1 Plan

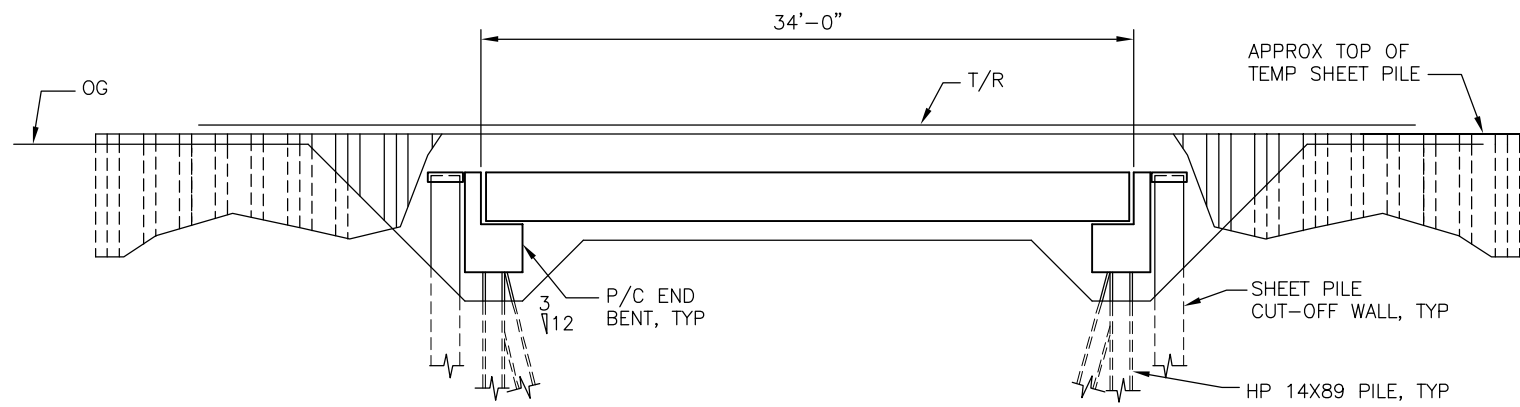

**SECTION A - STAGE II**

1" = 5'

NOTE:  
PRECAST WINGWALL AND PRECAST T-WALL  
UNITS NOT SHOWN FOR CLARITY.

**STAGE II**

1. EXCAVATE TRACK BED AND INSTALL PRECAST BOX GIRDERS, PRECAST FASCIA BEAM, PRECAST WINGWALLS, PRECAST T-WALL UNITS AND TEMPORARY BALLAST CURB.
2. BACKFILL BEHIND END BENT.
3. PLACE WATERPROOFING, BALLAST, AND RE-INSTALL NO. 2 TRACK.
4. SHIFT TRAFFIC TO NO. 2 TRACK (SINGLE TRACK OPERATION).

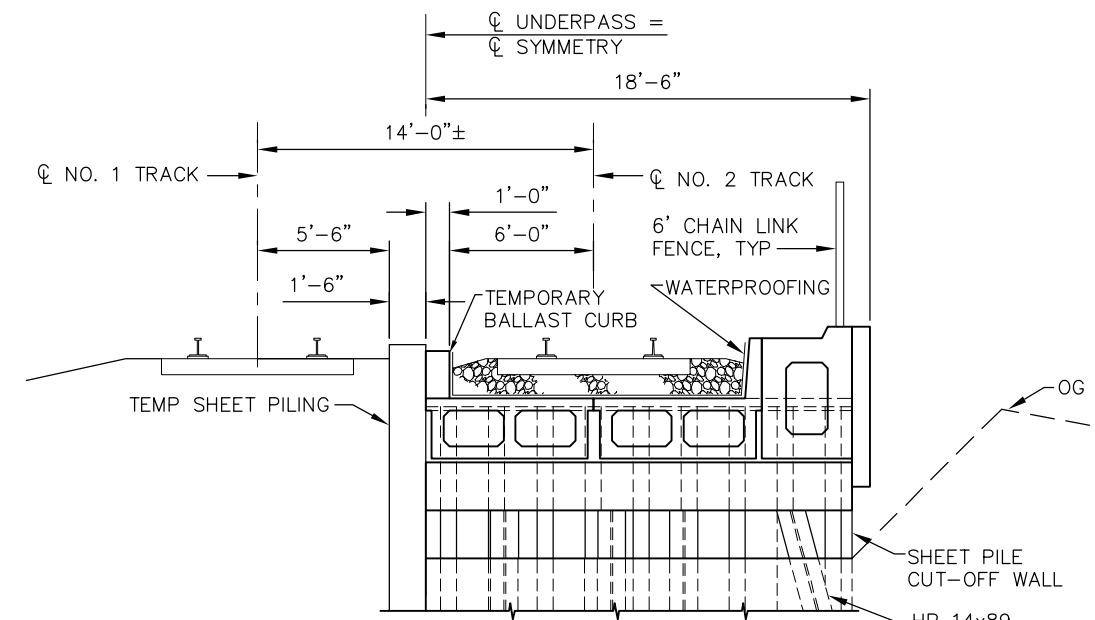

**SECTION B - STAGE II**

1/4" = 1'-0"

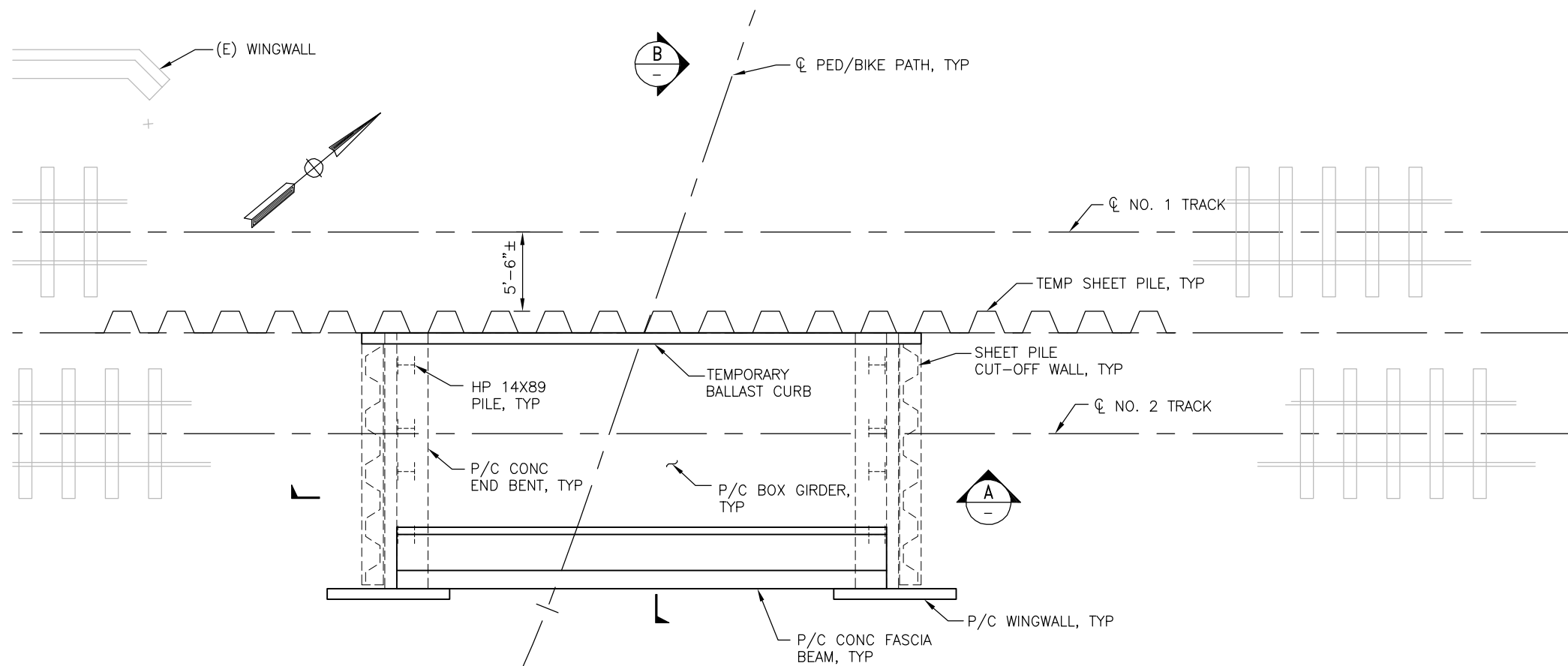

**PLAN - STAGE II**

1" = 5'

NOTE:  
PRECAST T-WALL UNITS  
NOT SHOWN FOR CLARITY.

**STAGE II**

I:\Sac\_County\60050869\_Watt-Roseville\CADD\Struct\Sheet\S-04.dwg Time:Apr29,2010 - 05:36pm  
Log:WaltZ Dimascale:48 1/4"=1'-0"  
Xrefs: XREF - Solid

REVISIONS				
MARK	DATE	DESCRIPTION	BY	CHKD
△				
△				
△				
△				

SCALE: VERTICAL: \_\_\_\_\_  
HORIZONTAL: \_\_\_\_\_

ORIGINAL SCALE IN INCHES  
FOR REDUCED PLAN

PROJECT ENGINEER: THOMAS R. BARNARD	REG. NO. C46384	DATE 3/31/11
DESIGNED BY: _____		
DRAWN BY: _____		
CHECKED BY: _____		

**AECOM**  
Technical Services, Inc.  
2335 American River Drive, Suite 100  
Sacramento, CA. 95825

Prepared for  
Sacramento County Municipal  
Services Agency  
Department of Transportation

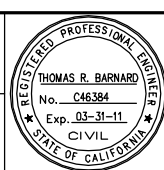

CI:	
FILE:	
DWG#:	

WATT AVENUE AT ROSEVILLE ROAD  
PEDESTRIAN & BICYCLE ACCESS IMPROVEMENTS

Stage 2 Plan

7.5  
SHEET  
OF





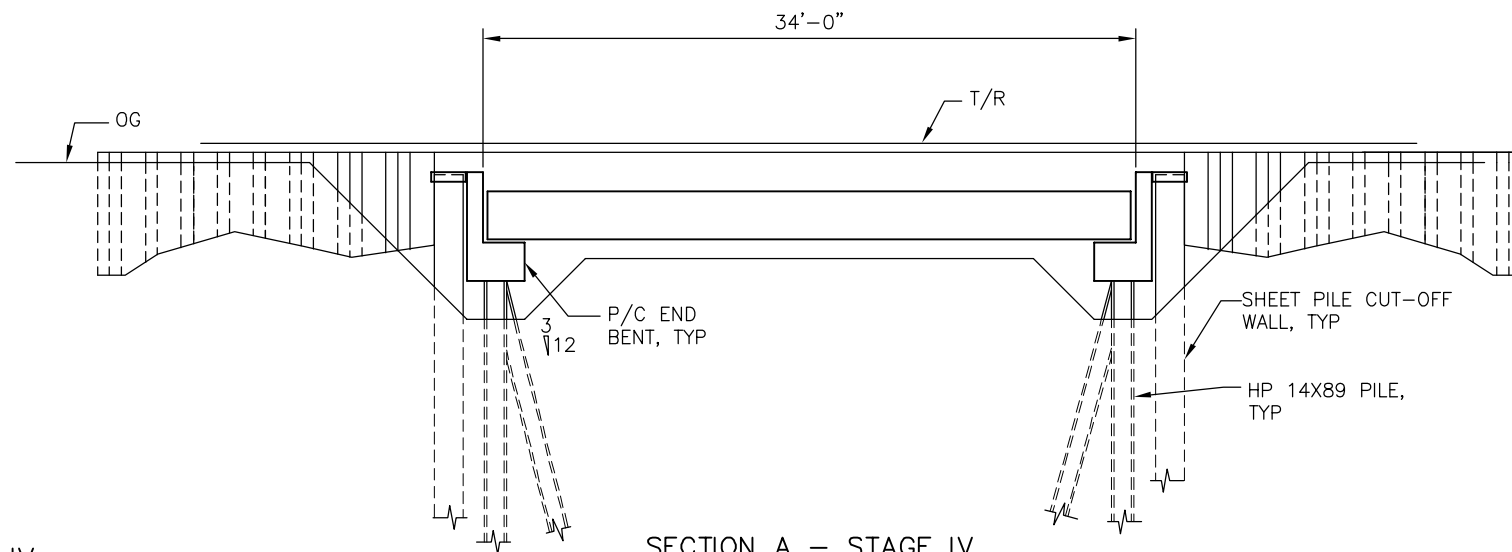

**SECTION A - STAGE IV**  
1" = 5'

NOTE:  
PRECAST WINGWALLS AND PRECAST T-WALL UNITS  
NOT SHOWN FOR CLARITY.

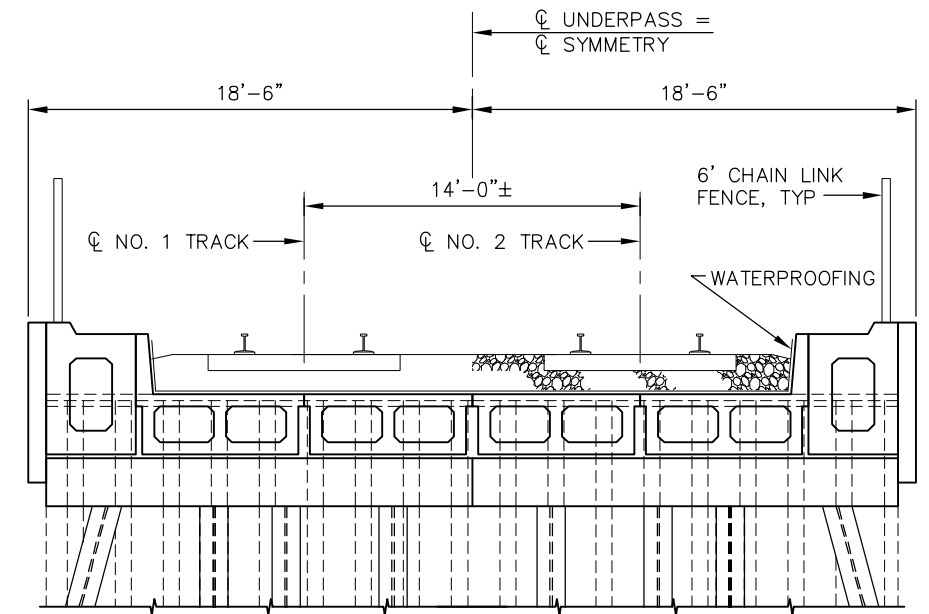

**SECTION B - STAGE IV**  
1/4" = 1'-0"

**STAGE IV**

1. EXCAVATE TRACK BED AND INSTALL PRECAST BOX GIRDERS, PRECAST FASCIA BEAM, PRECAST WINGWALLS, AND PRECAST T-WALL UNITS.
2. BACKFILL BEHIND END BENTS.
3. REMOVE TEMPORARY BALLAST CURB. PLACE WATER PROOFING, BALLAST, AND REINSTALL NO. 1 TRACK.
4. REMOVE SHEET PILING BETWEEN TRACKS; FILL ANY VOIDS WITH FLOWABLE BACKFILL OR GROUT.
5. SHIFT TO DOUBLE TRACK OPERATIONS.

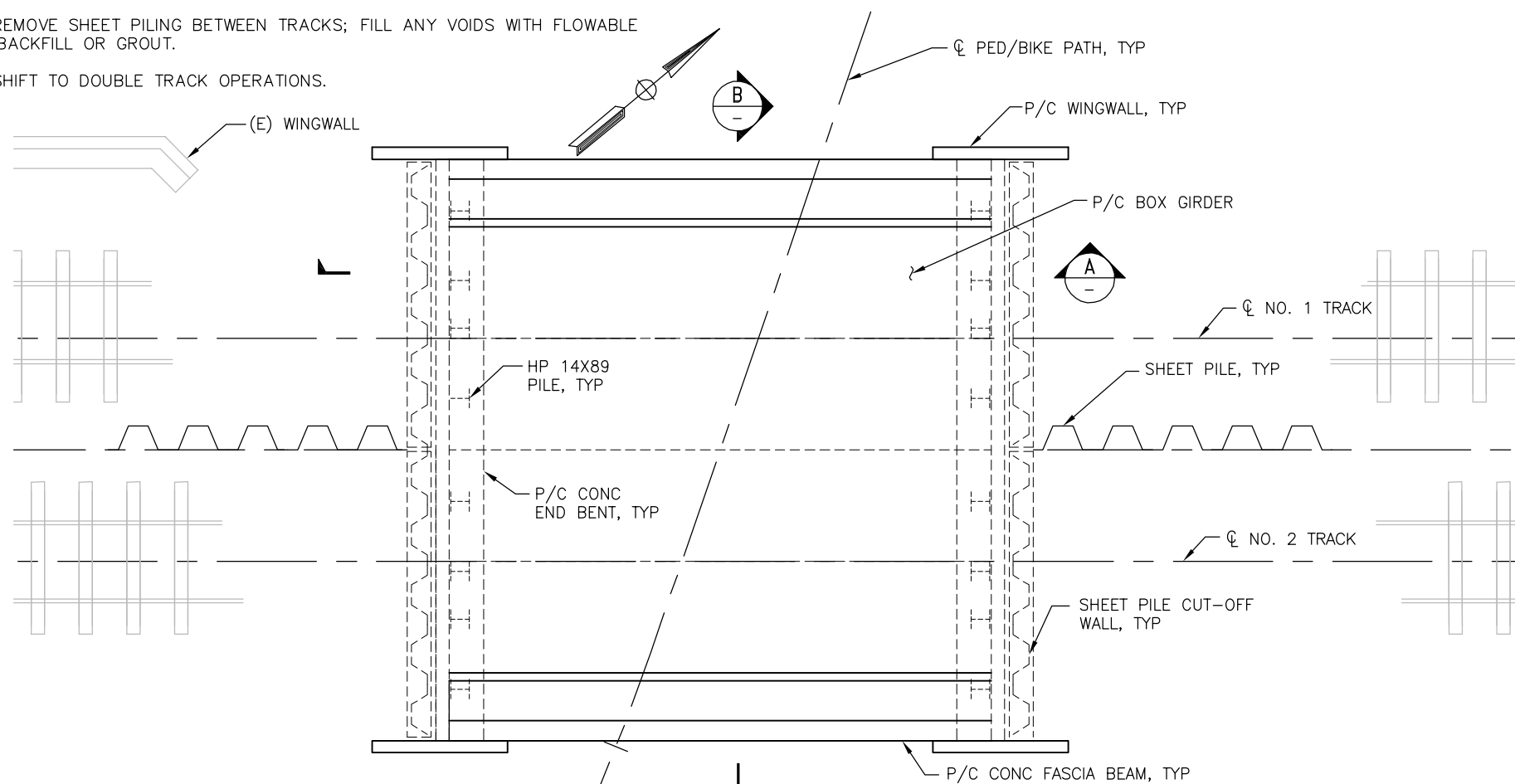

**PLAN - STAGE IV**  
1" = 5'

NOTE:  
PRECAST T-WALL UNITS  
NOT SHOWN FOR CLARITY.

**STAGE IV**

I:\Sac\_County\60050869\_Watt-Roseville\CA00\Struct\Sheet\S-04.dwg Time:Apr29,2010-03:37pm  
Log:Waltz DimScale:1/8 Scale:1/8  
Xrefs: XREF-Stage

REVISIONS				
MARK	DATE	DESCRIPTION	BY	CHKD
△				
△				
△				
△				

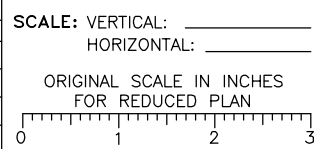

PROJECT ENGINEER: THOMAS R. BARNARD	REG. NO. C46384	DATE 3/31/11
DESIGNED BY: _____		
DRAWN BY: _____		
CHECKED BY: _____		

**AECOM**  
Technical Services, Inc.  
2335 American River Drive, Suite 100  
Sacramento, CA. 95825  
Prepared for  
Sacramento County Municipal  
Services Agency  
Department of Transportation

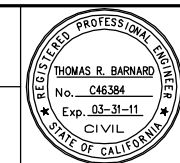

CI:	
FILE:	
DWG#:	

WATT AVENUE AT ROSEVILLE ROAD  
PEDESTRIAN & BICYCLE ACCESS IMPROVEMENTS  
Stage 4 Plan

7.7  
SHEET  
OF

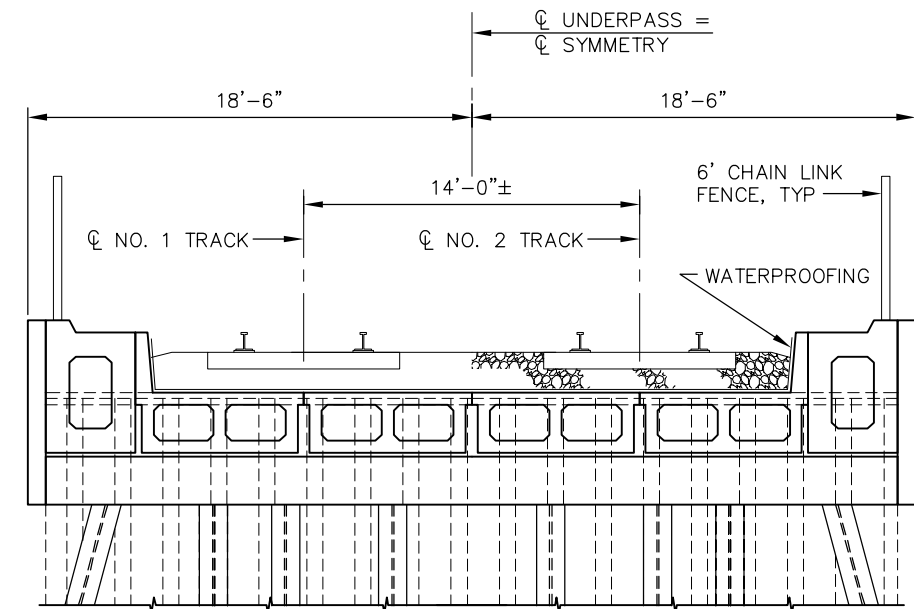
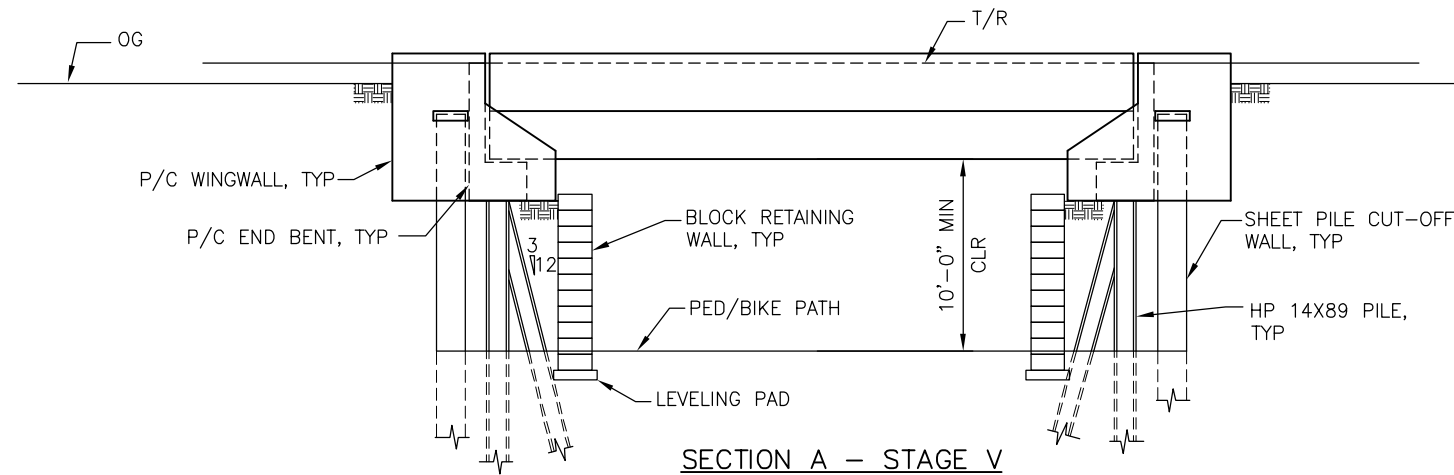

**STAGE V**

1. EXCAVATE BENEATH INSTALLED CONCRETE GIRDERS.
2. CONSTRUCT BLOCK RETAINING WALL IN FRONT OF EACH END BENT.
3. PLACE FLOWABLE BACKFILL BEHIND BLOCK RETAINING WALL.
4. CONSTRUCT PAVED PEDESTRIAN/ BIKE PATH.
5. INSTALL CHAIN LINK FENCE.

NOTE:  
PRECAST T-WALL UNITS  
NOT SHOWN FOR CLARITY.

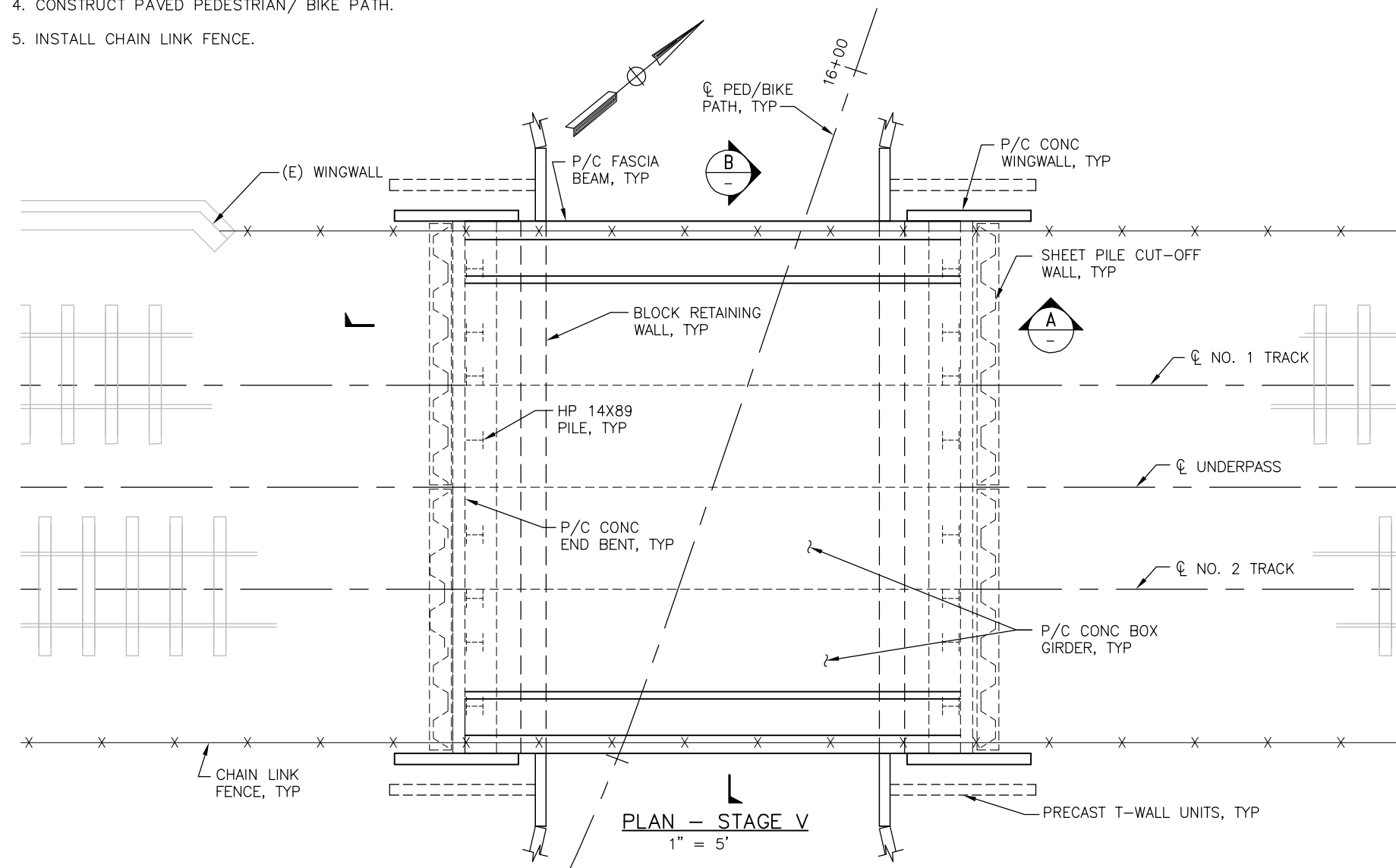

**STAGE V**

I:\Sac\_County\60050869\_Watt-Roseville\CA00\Struct\Sheet\S-04.dwg Time:Apr29,2010 - 03:37pm  
 Login:Waltz Dimascale:48 L1Scale:1 Images:  
 Xrefs: XREF-5.dwg

REVISIONS				
MARK	DATE	DESCRIPTION	BY	CHKD
△				
△				
△				
△				

SCALE: VERTICAL: \_\_\_\_\_  
 HORIZONTAL: \_\_\_\_\_  
 ORIGINAL SCALE IN INCHES  
 FOR REDUCED PLAN

PROJECT ENGINEER: THOMAS R. BARNARD  
 DESIGNED BY: \_\_\_\_\_  
 DRAWN BY: \_\_\_\_\_  
 CHECKED BY: \_\_\_\_\_

REG. NO. C46384 DATE 3/31/11  
**AECOM**  
 Technical Services, Inc.  
 2335 American River Drive, Suite 100  
 Sacramento, CA. 95825  
 Prepared for  
 Sacramento County Municipal  
 Services Agency  
 Department of Transportation

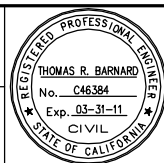

CI:  
 FILE:  
 DWG#:

WATT AVENUE AT ROSEVILLE ROAD  
 PEDESTRIAN & BICYCLE ACCESS IMPROVEMENTS  
 Stage 5 Plan

7.8  
 SHEET  
 OF



ID	Task Name	Duration	Start	Finish	Predecessors	2011					
						Qtr 2	Qtr 3	Qtr 4	Qtr 1	Qtr 2	Qtr 3
1	<b>Watt/Roseville Rd Ped/Bike Access Improvements</b>	<b>360 days</b>	<b>Tue 5/4/10</b>	<b>Mon 9/19/11</b>							
2	Concept Level Design	2 mons	Tue 5/4/10	Mon 6/28/10							
3	UPRR Review/Approval of Concept	1 mon	Tue 6/29/10	Mon 7/26/10	2						
4	Project Description	0.5 mons	Tue 7/27/10	Mon 8/9/10	3						
5	CEQA/NEPA Environmental Process	8 mons	Tue 8/10/10	Mon 3/21/11	4						
6	35% Design [Type Selection, Const Staging, etc.]	3 mons	Tue 7/27/10	Mon 10/18/10	3						
7	Internal QA/QC Process/Prepare submittal	0.25 mons	Tue 10/19/10	Mon 10/25/10	6						
8	UPRR Review/Approval of 35% Design	1 mon	Tue 10/26/10	Mon 11/22/10	7						
9	Response to UPRR Comments on 35% Design	0.5 mons	Tue 11/23/10	Mon 12/6/10	8						
10	65% Design [Response to comments, etc.]	3 mons	Tue 11/23/10	Mon 2/14/11	8						
11	Internal QA/QC Process/Prepare submittal	0.25 mons	Tue 2/15/11	Mon 2/21/11	10						
12	UPRR Review/Approval of 65% Design	1 mon	Tue 2/22/11	Mon 3/21/11	11						
13	Response to UPRR Comments on 65% Design	0.5 mons	Tue 3/22/11	Mon 4/4/11	12						
14	Final Design [PS&E, Bid Documents, etc.]	3 mons	Tue 4/5/11	Mon 6/27/11	5,12,13						
15	Advertise/Bid/Award	3 mons	Tue 6/28/11	Mon 9/19/11	14						

**Notes:**

1. This Design process should likely be extended to 24 calendar months to allow for extended UP project review & coordination, and Stakeholder design input.
2. This same 24 month time frame could also accommodate just the westerly pathway option, or the simultaneous east and west pathway option.

Project: Watt-RosevillePed\_Bike\_050  
Date: Tue 5/4/10

Task		Milestone		External Tasks	
Split		Summary		External Milestone	
Progress		Project Summary		Deadline	



RCVD BY: \_\_\_\_\_

IN EST: \_\_\_\_\_

OUT EST: \_\_\_\_\_

**BRIDGE:** Watt Ave/Roseville Rd Ped/Bike Access [East Crossing] **BR. No.:** \_\_\_\_\_  
**TYPE:** PC/PS Dbl Cell Box Girder with Exterior Fascia Beams  
**CU:** NA  
**EA:** NA

**DISTRICT:** \_\_\_\_\_  
**RTE:** \_\_\_\_\_  
**CO:** \_\_\_\_\_  
**PM:** \_\_\_\_\_

**LENGTH:** 34.00      **WIDTH:** 35.50      **AREA (SF) =** 1,207

**DESIGN SECTION:** AECOM  
**# OF STRUCTURES IN PROJECT :** 01      **EST. NO.** 1  
**PRICES BY :** T. Barnard      **COST INDEX:** NA  
**QUANTITIES BY:** \_\_\_\_\_      **DATE:** 4/1/2010  
**QUANTITIES CHECKED BY:** \_\_\_\_\_      **DATE:** \_\_\_\_\_

	CONTRACT ITEMS	TYPE	UNIT	QUANTITY	PRICE	AMOUNT
1	Construction Area Signs		LS	1	\$5,000.00	\$5,000.00
2	Traffic Control		LS	1	\$15,000.00	\$15,000.00
3	Railroad Flagging per Day		EA	25	\$800.00	\$20,000.00
4	Storm Water Polution Control		LS	1	\$7,500.00	\$7,500.00
5	Path Excavation/Rough Grading		CY	2,500	\$30.00	\$75,000.00
6	Remove/Reconstruct Track		LF	120	\$200.00	\$24,000.00
7	Tie Back Retaining Wall @ Pump Station		SF	480	\$85.00	\$40,800.00
8	Class 2 Agg Base - Path Subgrade		CY	900	\$60.00	\$54,000.00
9	Hot Mix Asphalt [HMA] Concrete		Ton	300	\$95.00	\$28,500.00
10	T-Wall Retention System		SF	1,000	\$65.00	\$65,000.00
11	Temporary Sheet Piling		SF	1,500	\$40.00	\$60,000.00
12	Permanent Sheet Piling		SF	900	\$65.00	\$58,500.00
13	PC/PS Box Girder UP [2 Tracks @ 34ft ea includes fascia bm]		LF	68	\$5,500.00	\$374,000.00
14	Waterproofing & Deck Drainage System		SF	1,020	\$20.00	\$20,400.00
15	Landscaping & Irrigation		LS	1	\$60,000.00	\$60,000.00
16	Lighting		LS	1	\$20,000.00	\$20,000.00
17						
18						
19						
20	Note: Right of way and final					
21	Engineering design not included.					
22						
23						
24						
25						
26						
27						
28						
29						
30						

**ROUTING**  
 1. DES SECTION

SUBTOTAL	\$927,700
MOBILIZATION ( @ 10 % )	\$92,770
SUBTOTAL ITEMS	\$1,020,470
CONTINGENCIES (@ 25%)	\$255,118
TOTAL COST	\$1,275,588
GRAND TOTAL	\$1,275,588
FOR BUDGET PURPOSES - SAY	<b>\$1,280,000</b>

**COMMENTS:**  
 \_\_\_\_\_  
 Cost for utility relocations not included.  
 \_\_\_\_\_  
 \_\_\_\_\_

### **AECOM Comments Regarding Cost and Schedule Considerations for the total replacement of the UP Underpass Structure**

AECOM estimates that the replacement of the existing underpass structure will likely take a minimum of 18-24 months for construction. The primary driver will be staging the construction so the disruption to vehicular and rail traffic is minimized. Currently, there are three lanes that choke down to two at Peacekeeper in the northbound. Maintaining 2 lanes in each direction thru construction may require a local detour to the east in order to allow the profile of Watt to be lowered for permanent clearance to be achieved.

AECOM considers it likely that UP will require a double track shoofly and that will require a temporary UP structure to carry the shoofly tracks through the work zone. Signal work within the area to support the shoofly would need to take place in advance of the shift of rail traffic and is usually a long lead item with UP. AECOM provides a rough estimate of the construction price at around \$15-\$20K/LF per track or \$13.5M-\$18M for the railroad structure; another \$4-5M for the temporary shoofly track and structures and another \$8M-\$12M for the roadway detours and permanent improvements. A grand total estimate of around \$35M-\$40M for the replacement.